

### SECTION 20: WCC II to WCC III GLOBAL BRIDGE MANUAL

#### Overview

The “WCC II to WCC III Global Bridge” board provides a means for the new WCC III system to pass information to and from the old WCC II system. A single “WCC II to WCC III Global Bridge” board can simulate (mirror) up to 8 WCC II SAT II Controllers. A “WCC II to WCC III Global Bridge” can also share Global Binary and Global Analog information from WCC II to WCC III and current values of the simulated (mirrored) satellites from WCC III to WCC II. But this is a one way data flow for the Global data, the direction is from the WCC II system to the WCC III system.

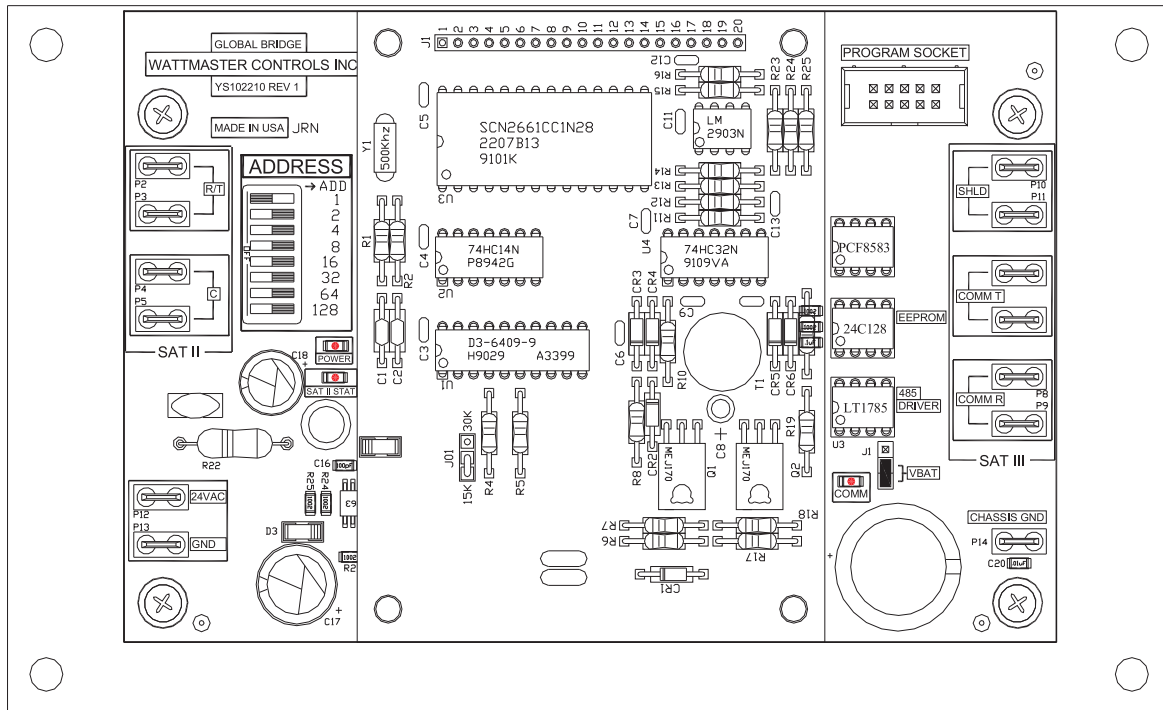

Figure 20-1: Global Bridge Board

### Setup Global Bridge

#### WccUtility.EXE Program Setup Considerations and Limitations for Global Bridge

To setup the Global Map for the “WCC II to WCC III Global Bridge”, you only have to fill out the data in one “SetGlobalMapView” window even if you have multiple “WCC II to WCC III Global Bridges”. This is because all of the “WCC II to WCC III Global Bridges” will have the same global analog/binary value that will come from the WCC II front-end computer.

There are no limitations to the number of global analogs or global binaries that you can setup from within the “SetGlobalMapView” window. Of course, you cannot setup more than the WCC II limitations of 128 global analogs and 256 global binaries.

The BACKTASK.EXE program that is running on the WCC III - MCD requires that the WccUtility.exe program be connected (via an IP connection) to the WCC III - MCD, that the WccUtility.exe program be opened and running at all times, and that the “SetGlobalMapView” window also be opened at all times. This IP connection must be made so that BACKTASK.EXE can fetch and retrieve the global values from the “old” WCC II system.

If you close the “SetGlobalMapView” window or the WccUtility.exe program, the BACKTASK.EXE program will not be able to retrieve any global values from the “old” WCC II system. This means that the “SetGlobalMapView” window that does the global analog and global binaries value transfers will not transfer these global analog and global binaries values from the “WCC II to WCC III Global Bridge” board to BACKTASK.EXE program of WCC III - MCD.

## SET GLOBAL MAP VIEW

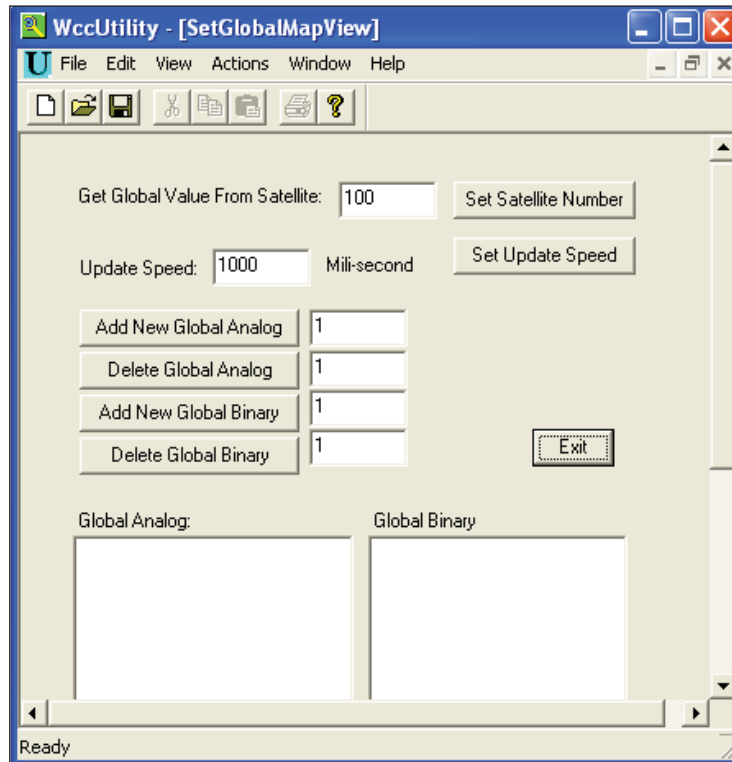

Figure 20-2: Set Global Map View Window

From the WCCUtility.EXE program there are two choices for the “WCC II to WCC III Global Bridge” board. The first selection choice is <Setup Global Map>. This is where global information can be sent from the WCC II system to the WCC III - MCD.

Get Global Value From Satellite: Enter the address for the “WCC II to WCC III Global Bridge” board. This value should be higher than the last satellite number on your system. After entering the address, press the <Set Satellite Number> button to lock in the address. NOTE: The “WCCII to WCCIII Global Bridge” will not show on the *Satellite Summary Screen*.

Set Update Speed: xxxx Milli-second: 1000 milliseconds is entered for each “WCC II to WCC III Global Bridge” board on the system. If you have three “WCC II to WCC III Global Bridge” boards, then a value of 3000 milliseconds needs to be entered for each “WCC II to WCC III Global Bridge” board. When desired value is entered, press the <Set Update Speed> button to lock in the “Set Update Speed” value.

<Add New Global Analog> Enter the number of the global analog you wish to send from the WCCII to the WCCIII and press the button. The global will be added to the Global Analog field at

the bottom of the screen. There is no limitation to the number of global analogs entered.

<Delete Global Analog> Enter the number of the global analog you wish to delete from the Global Analog box and press the button. The global analog will disappear from the list.

<Add New Global Binary> Enter the number of the global binary you wish to send from the WCCII to the WCCIII and press the button. The global will be added to the Global Binary field at the bottom of the screen. There is no limitation to the number of global binaries entered.

<Delete Global Binary> Enter the number of the global binary you wish to delete from the Global Binary box and press the button. The global binary will disappear from the list.

---

NOTE: To receive global analog and global binary values on the WCC III system from the WCC II system, the mode for the analog global and binary global on the WCC III system must be set to external. See Section 3 for programming globals.

---

#### SET BRIDGE MAP

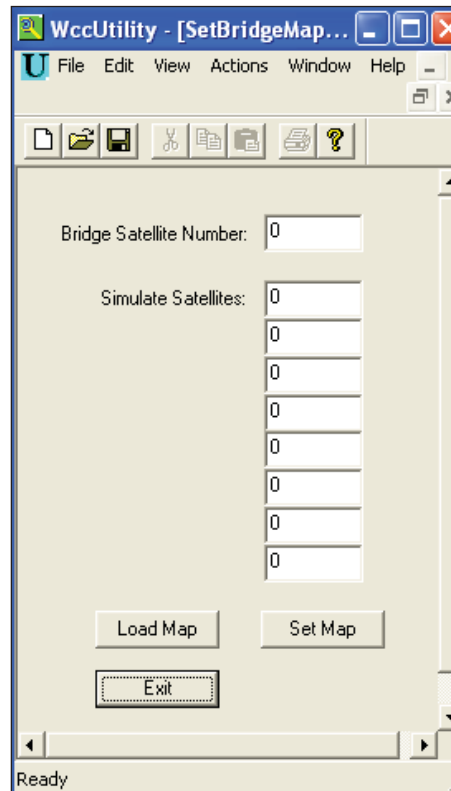

Figure 20-3: The Set Bridge Map Window

From the WccUtility.exe program there are two choices for the “WCC II to WCC III Global Bridge” board. The second selection choice is <Set Bridge Map>. This is where satellite information can be sent from the “new” WCC III - MCD to the old WCC II system.

**Bridge Satellite Number:** Enter the address for the “WCC II to WCC III Global Bridge” board. This value should be higher than the last satellite number on your system.

**<Load Map>** After you type in the address Bridge Satellite (SAT III) number, press the <Load Map> button to see your simulated satellites (SAT II) that you have selected for simulation.

**Simulate Satellites:** Enter the satellite number(s) of which you would like to simulate. There is a maximum of eight satellites per “WCC II to WCC III Global Bridge” board. These are the SAT II simulated addresses.

**<Set Map>** After entering (or adding) satellites to the “WCC II to WCC III Global Bridge” board, you must press the <Set Map> button to send the map information to the “WCC II to WCC III Global Bridge” board. After the map information has been received, the “WCC II to WCC III Global Bridge” board will capture the current values from the satellites on the WCC III side and provide them to the old BACKTASK program that is running on the WCC II system side for use in the simulated SAT II satellite logical address.

# 20. GLOBAL BRIDGE BOARD INSTALLATION

## Troubleshooting Communication Loops

### Troubleshooting the WCC III RS-485 Communications Loop

What is the WCC III RS-485 communications loop voltage measurement on a SAT III controller or on a WCC II to WCC III Global Bridge board?

There are two conditions for Voltage measurements of the WCC III RS-485 communications loop.

1st Condition: The WCC III RS-485 communications loop is plugged into a SAT III controller or on a WCC II to WCC III Global Bridge board, and you are measuring the voltage at the SAT III controller or on a WCC II to WCC III Global Bridge board.

On the RS-485 loop for a SAT III controller or on a WCC II to WCC III Global Bridge board, the "T" (+) and "R" (-) terminals should measure "T"(+) @ 3.00VDC and "R"(-) @ 2.7VDC voltages. These are approximate values, but should be used as base line measurements.

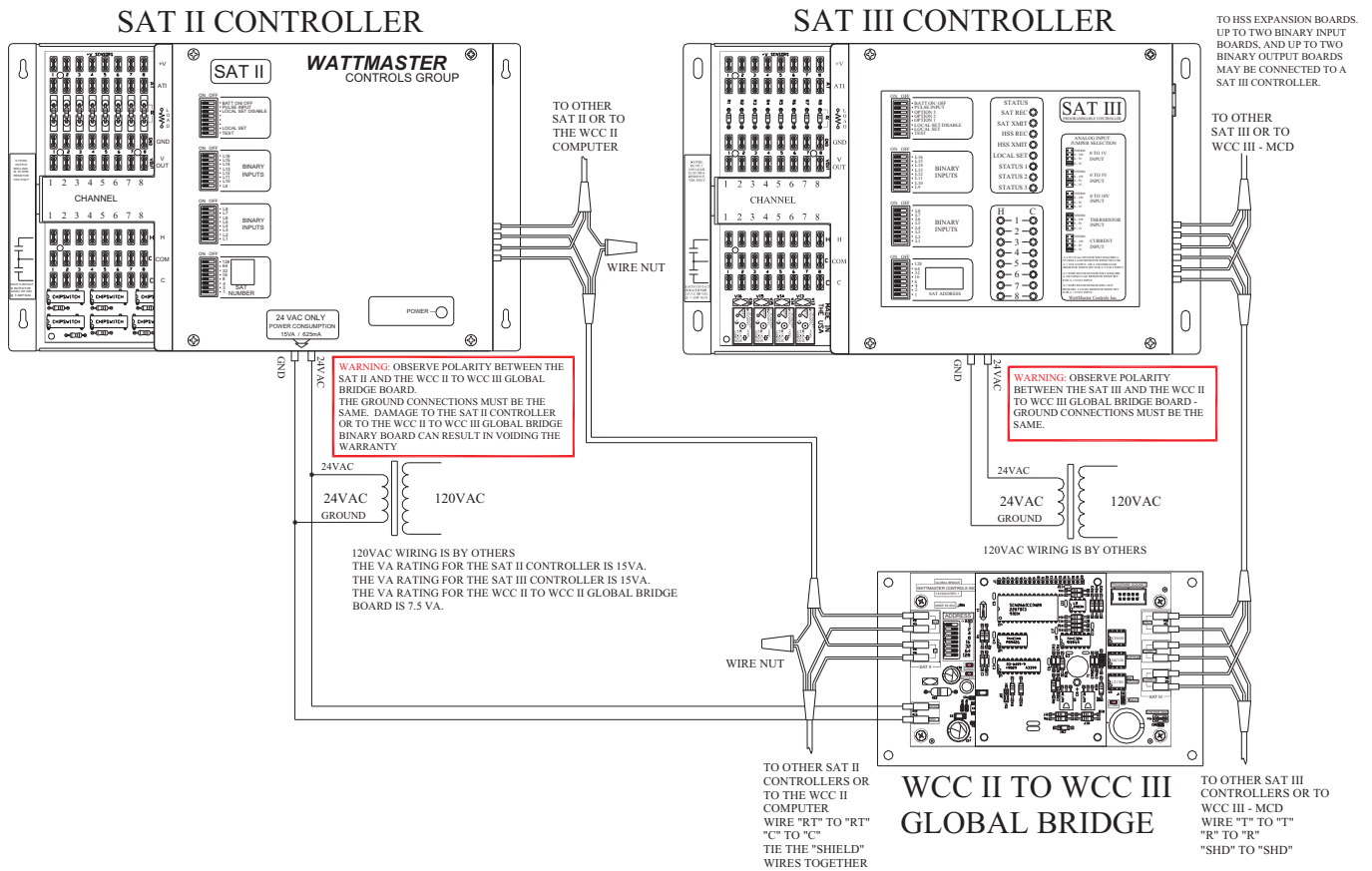

Figure 20-4: Wiring diagram showing how to connect the WCC III to WCC II systems using the WCC II to WCC III Global Bridge board.

### Troubleshooting Communication Loops

2nd Condition: The WCC III RS-485 communications loop is not plugged into a SAT III controller or on a WCC II to WCC III Global Bridge board, and you are measuring the voltage.

On the RS-485 loop for a SAT III controller or, on a WCC II to WCC III Global Bridge board the "T" (+) and "R" (-) terminals should measure "T"(+) @ 3.25VDC and "R"(-) @ 3.25VDC voltages. These are approximate values, but should be used as base line measurement. More than half a volt either way should be considered a suspected problem.

The RS-485 driver chip is a field-replaceable part. It is WattMaster Controls part #ID001785. It is the same RS-485 driver that WattMaster Controls uses on all of its product lines.

The WCC II to WCC III Global Bridge board has 1000 Volts of optical isolation for the RS-485 driver circuit. It should also be resistant to having an external AC or DC voltage (up to 50 VAC/VDC) from being applied to the "R", "T", and "SHLD" connections. There is no protection provided for 120 VAC or greater line voltages for the "R", "T", and "SHLD" connections.

### Troubleshooting the WCC II Manchester Communications Loop

What is the WCC II Manchester communications loop voltage measurement on a SAT II, SAT 2c, or SAT 2d?

It is not recommended to use a voltmeter to troubleshoot the WCC II communications loop.

This is a really difficult voltage to measure. It really requires an "Oscilloscope" to measure it correctly. But if you have a really good digital hand held meter that can measure "AC Milli-Volts" (the cost of such a meter is about \$300 or more), you can measure the voltage between the R/T and C connections (polarity doesn't matter). A fluctuating AC voltage between 100mVAC to 200mVAC should be present. Your meter should also have a frequency counter on it, and the frequency should fluctuate between 0 Hz and 15.6KHz.

When troubleshooting the WCC II communications loop, the following is the recommended procedure:

Bad or no WCC II Communications. Do the Resistance Checks:

Step 1: Check the resistance between R/T and C on the SAT with the WCC II Communication loop disconnected and with the power to the WCC II to WCC III Global Bridge off.

- a. The resistance should be about 120 ohms (+/- 15 ohms). If it is, then it is probably OK and you should test the rest of the WCC II communications loop. Each SAT II controller should measure this resistance when the WCC II Communication loop is disconnected and with the power to the SAT II controller turned off.
- b. If the reading is less than 100 ohms, the replacement of the Manchester Communication board is required.
- c. If the reading is more than 135 ohms, the replacement of the Manchester Communication board is required.

Step 2: SAT II / WCC II - Termination Resistors

- a. Is there a Terminating Resistor on the loop? This may or may not be a problem. Terminating resistors are connected across the RT / C connections on the SAT, usually at the end of the physical run of wire.

---

NOTE: If the WCC II communication loop splits into a "T", then there may be TWO or more of these terminating resistors. The value of the terminating resistors may vary but should be between 10 and 50 ohms. Also, if you are on a job that has these terminating resistor(s), then you should realize that this job has had a problem before in the past with this echoing effect. Great care must be taken so that these terminating resistor(s) are put back on or that you note where they were in case there is still a problem.

---

### Troubleshooting Communication Loops

Step 3: SAT II controller Manchester boards' impedance mismatching problem:

- a. When installing a new SAT II controller to your system, the new SAT II controller appears to not work and/or other previous working SAT II controllers now stop communicating. This is a classic Manchester board impedance mismatching problem. It is a difficult problem to fix. The fix involves updating all of your SAT II controllers' Manchester boards to the current impedance.
- b. Newer SAT II controllers Manchester boards have a different RT to C resistance impedance than the much older Manchester boards (more than 15 years old). The "New" RT to C resistance should read about 120 ohms (+/-15 ohms).
- c. Older Manchester boards have RT to C resistance impedance's of 18 (+/- 5) ohms or some even have impedances of over 200 ohms. To guarantee the proper operation of the WCC II communications loop, all SAT II controllers Manchester boards should have the same RT to C resistances. It has been WattMaster's experience that when the SAT II controllers' Manchester boards' impedances match, the WCC II communications loop will work. Also, it is recommended that the whole SAT II controller as a complete assembly will need to be rebuilt and have all of the latest upgrades preformed.

Step 4: Have you run the LOOPTEST diagnostics on the WCC II computer?

- a. The Looptest program must be run with 1000 passes per SAT II controller in order to determine if a WCC II communication problem exists with a particular SAT II controller.
- b. Make note of any failures of all of your SAT II controllers on the loop as this will be useful in determining if a WCC II communications problem exists.
- c. If a SAT is failing a lot of passes (20 %), then disconnect it from the communications loop. It could be causing an intermittent communications problem with other SAT II controllers that are on the WCC II communications loop.
- d. It would be also helpful if you know how the communications loop was ran - if it was split into multiple loops converging into one at some point - because one of these WCC II communications loops may be cut or disconnected, and this may be the source of your problem.

---

NOTE: Before testing the Z-80 board for loop test diagnostics, the clock chip on the WCC II front-end computer's Z-80 board must be initialized. This is best done by setting the time and date from within the WCC II program via the System Parameters Screen. If the time and date are not initialized, this could cause 3 or 4 failed passes per 1000 passes.

---

## 20. GLOBAL BRIDGE BOARD INSTALLATION

### WCC II Manchester Boards

#### WCC II Manchester Communication Boards

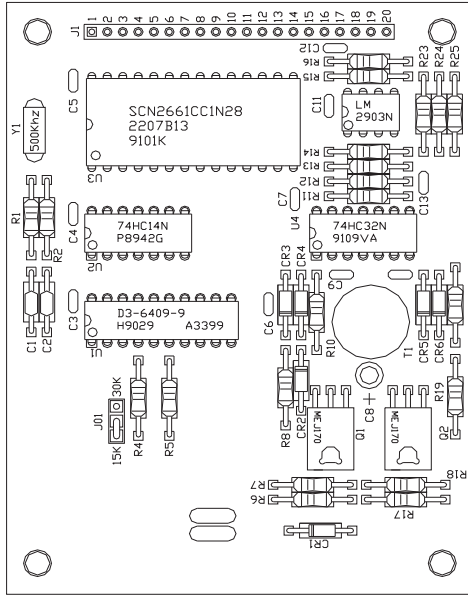

SAT II MANCHESTER BOARD

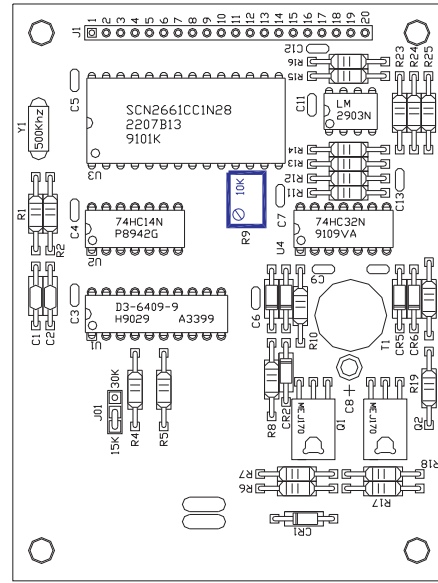

SAT II MANCHESTER BOARD WITH BLUE POT - DO NOT USE

Figure 20-5: SAT II Manchester Boards

WattMaster Controls, Inc. in the past has produced two types of Manchester Communication Boards - the early Manchester Communication Board with an adjustable “Blue Potentiometer” and the later Manchester Communication board without the “Blue Potentiometer”. Use of the early Manchester Communication Board with the “Blue Potentiometer” is not recommended for use with the WCC II to WCC III Global Bridge board.

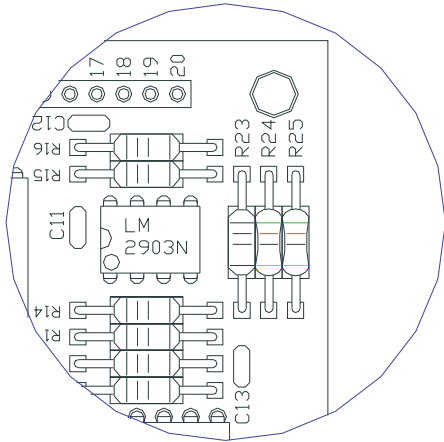

**SAT II MANCHESTER BOARD  
50 OHM JUMPER (R24 & R25)**

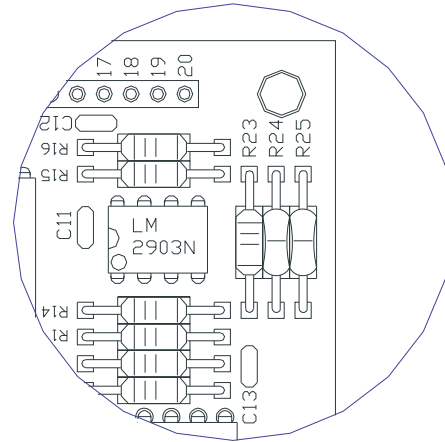

**SAT II MANCHESTER BOARD  
ZERO OHM JUMPER (R24 & R25)**

Figure 20-6: SAT II Manchester Board Jumpers

Please note the following:

- The later Manchester Communication Board will need to have the 50 ohm load resistors installed on it instead of the zero ohm jumper.
- Location R24 and R25 should have a 50 ohm load resistor installed.
- A zero ohm jumper has a single Black band on it. A 50 ohm resistor should have the color code of “GREEN” “BROWN” “BLACK” “GOLD”.

## 20. GLOBAL BRIDGE BOARD INSTALLATION

---

---